

Specification

For

LCD Module

TS-12864A-2

TS-12864A-2 Dot Matrix LCD Module (Graphic Type)

■FEATURES

- Module: graphic LCD arranged as 128 x 64 dots with LED Back-light*(Yellow/Green)
- Glass Type: STN
- Viewing Direction : 6 'clock (bottom view)
- Display color: Green
- Background color: Yellow
- Polarizer mode: Positive, Reflective/Transflective
- Driving Method: 1/64Duty Cycle, 1/9 Bias
- Glass to PCB: ZEBRA CONNECTOR
- Dot Size : 0.48x 0.48 mm
- Dot Pitch : 0.52 x 0.52 mm

■ABSOLUTE MAXIMUM

Item	Symbol	Standard value	Unit
Power Supply Voltage	Vdd	-0.3 ~ +7.0	V
Power supply for LCD Drive	Vlcd	Vdd-19.0 ~ Vdd+0.3	V
Input Voltage	Vin	-0.3 ~ Vdd+0.3	V
Operating Temperature	Top	0 ~ +50	°C
Storage Temperature	Tstg	-10 ~ +60	°C

■MECHANICAL PARAMETED/I

Item	Description	Unit
PCB Dimension	93.0 x 70.0 x 1.6	mm
LCD Dimension	84.0 x 51.0 x 2.6	mm
View Dimension	70.6 x38.6	mm
Outline Dimension	93 x 70.0 x8.0/13.5*	mm

■PIN ASSIGNMENT

Pin NO.	Symbol	Level	Function
1	VSS	0V	Power Ground
2	VDD	+5V	Power supply
3	V0 ?	--	For LCD drive voltage(variable)
4	D/I ?	H/L	H: Display Data, L: Display Instruction
5	R/W ?	H/L	H: Read Signal, L: Write Signal
6	E ?		Enable Signal
7-14	DB0-DB7	H/L	Date bus
15	CSA ?	H/L	Select chip
16	CSB ?	H/L	Select chip
17	RES ?	H/L	Reset Signal
18	VEE ?	-15V	Negative voltage(-15V)to LCD
19	LED(+)	--	Power (+)for LED Backlight
20	LED(-)	--	Power (-)for LED Backlight

■ELECTRICAL CHARACTERISTICS

DC Characteristics(Ta==25°C;Vdd=5.0V±10%)

PARAMETER		SYMBOL	CONDITION	MIN	TYP	MAX	UNIT
Operating Voltage(1)		VDD		4.5	5.0	5.5	V
Input Voltage	High	Vih	E,R/W,D/I,DB0~DB7	2.0	--	VDD	V
	Low	Vil	Terminals	0	--	0.8	
Output Voltage	High	Voh	DB0~DB7,	2.4	--	--	V
	Low	Vol	Terminal	--	--	0.4	
Operating Current		Idd	During Display	--	--	2750	uA

AC characteristics ($V_{dd}=5V \pm 10\%$, $V_{ss}=0V$ $T_a=25^\circ C$)

Characteristic	Symbol	Min.	Max.	Unit
E Cycle	Tcyc	1000	--	ns
E High Level Width	Pweh	450	--	
E Low Level Width	Pwel	450	--	
E Rise Time	Tr	--	25	
E Fall Time	Tf	--	25	
Address Set-Up Time	Tas	140	--	
Address Hold Time	Tah	10	--	
Data Set-Up Time	Tdsw	200	--	
Data Delay Time	Tddr	--	320	
Data Hold Time(Write)	Tdhw	10	--	
Data Hold Time(Read)	Tdhr	20	--	

Writing timing

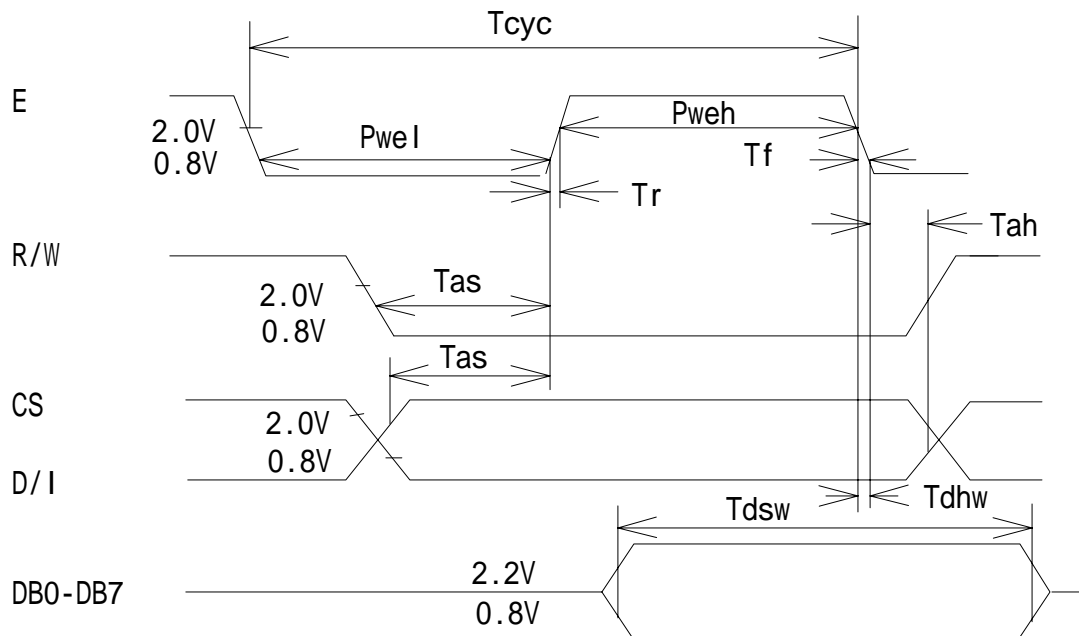

Reading Timing



■ CONTROL and DISPLAY COMMAND

Instruction	R/W	D/I	DB7	DB6	DB5	DB4	DB3	DB2	DB1	DB0	Function	
Display on/off	L	L	L	L	H	H	H	H	H	L/H	Controls the display on or off. Internal status and display RAM data is not affected. L:OFF,H:ON	
Set Address	L	L	L	H	Y address (0~63)						Sets the Y address in the Y address counter.	
Set Page (X Address)	L	L	H	L	H	H	H	page (0~7)			Sets the X address at the X address register.	
Display Start Line	L	L	H	H	Display start line (0~63)						Indicates the display data RAM display at the top of the screen	
Status read	H	L	B U S Y	L	O N / O F F	R E S E T	L	L	L	L	Read the status : busy 1:working,0:ready ADC 1:clockwise output 0:counterclockwise ON/OFF 1:disp off 0:disp on RESET 1:reset 0:normal	
Write Display Data	L	H	Write Data									Write data (DB0:7) into display data RAM. After writing instruction, Y address is increased by 1 automatically.
Read Display Data	H	H	Read Data									Read data (DB0:7) from display data RAM to the data bus

ASSEMBLY DIAGRAM

TECHSTAR

TS12864A-2

